

**AIRBORNE ELECTRONICS**  
**350A PROPELLER GOVERNOR**  
**INSTALLATION INSTRUCTIONS**  
**and SERVICE NOTES**

TABLE OF CONTENTS:

|                               |         |
|-------------------------------|---------|
| INSTALLATION INSTRUCTIONS     | Page 1  |
| GROUND TEST                   | Page 3  |
| FLIGHT TEST                   | Page 4  |
| IF TROUBLE, WHERE TO START    | Page 4  |
| AIRFRAME SYSTEMS TEST (S/N 1) | Page 5  |
| DEFECTIVE MAGNETOS (S/N 2)    | Page 8  |
| WRONG GEARS (S/N 3)           | Page 8  |
| BRUSH SERVICE (S/N 4)         | Page 8  |
| INACCURATE PANEL TACH (S/N 5) | Page 9  |
| INTERMITTENT PROBLEMS (S/N 6) | Page 10 |
| BLOWN FUSES (S/N 7)           | Page 11 |
| OPEN MAG LEAD (S/N 8)         | Page 11 |
| MANUAL WIRING (S/N 9)         | Page 11 |
| HIDDEN SCREWS (S/N 10)        | Page 12 |
| WEIGHT and BALANCE (S/N 11)   | Page 12 |

|          |                               |
|----------|-------------------------------|
| FIGURE A | WIRING DIAGRAM                |
| FIGURE B | WRONG GEARS                   |
| FIGURE C | EARLY WIRING                  |
| FIGURE D | LATE WIRING                   |
| FIGURE E | KNOB MOUNTING and TEMPLATE    |
| FIGURE F | CHASSIS MOUNTING              |
| FIGURE G | FLIGHT MANUAL SUPPLEMENT      |
| FIGURE H | SUPPLEMENTAL TYPE CERTIFICATE |

**SAVE THESE DOCUMENTS**

Keep these documents with the aircraft papers to aid in troubleshooting problems in the future. FBO's, please pass this package on to the aircraft owner. Thank you.

**AIRBORNE ELECTRONICS**  
2655 N. FITCH MTN. RD.  
HEALDSBURG, CA 95448  
(707) 542-6053

# AIRBORNE ELECTRONICS

## INSTALLATION INSTRUCTIONS

### 1. REMOVAL OF OLD GOVERNOR:

- a. Disconnect the Cannon connector and the 2 flex drives from the governor.
- b. Remove the 4 screws that secure the old governor to the long spacer nuts. Leave the spacers in place.
- c. Remove flex drive cable and associated "T" drive. It may be difficult to remove the "T" drive from the accessory case without removing a magneto. It is practical to leave the "T" drive in place until a magneto is removed for other reasons. However, the panel tach will be more reliable with the "T" drive removed. By far, the easiest way to remove the flex cable, is to cut it in two.
- d. Reseal the opening in the firewall where the flex drive cable was removed.
- e. Remove the aluminum propeller control knob, the placard under the knob, and the knob flex drive assembly. If the 3 screws that secure the drive assembly are not obvious, see Service Note 10, page 12, titled "HIDDEN SCREWS". Save the knob. Set everything else aside.

### 2. INSTALLATION OF NEW KNOB RHEOSTAT:

- a. Remove the screws that secure the control column collar (aluminum ring that the gust lock slides into). Slide the collar out of the way of the panel opening.
- b. Remove the shoulder nut from the rheostat (see figure E) and check that it will fit into the hole left by the old knob drive assembly. Some aircraft require enlargement of this hole to 5/8 inch dia.
- c. While sitting normally on the seat, feed the new 7 pin connector, its associated wires, and the rheostat through the control column opening. Position the rheostat with the lock washer on the engine side of the panel in the knob hole as shown in the drawing.
- d. Tighten the shoulder nut and rotate the rheostat as necessary to achieve 24 inch-pounds tightness and the shoulder nut slot in the 9 o'clock position.

## AIRBORNE ELECTRONICS

### 3. REMOVAL OF OLD WIRING AND CONNECTION OF NEW WIRING:

- a. Position yourself on your back on the aircraft floor so as to see up into the panel area.
- b. Route and secure the new wires such that:
  - i. The connector will reach the new governor's connector when installed on the 4 spacers.
  - ii. The "A" lead end is at the prop control toggle switch.
  - iii. The "C" and "D" leads go forward towards the firewall.
  - iv. The "H" lead goes toward the firewall to the grommet that the magneto grounding leads come through.
  - v. The "B" lead is near the right front spacer where it will be grounded.
  - vi. All wires are secured with cable ties clear of control cables or other moving parts.
- c. Position yourself on the aircraft floor so as to see the back of the propeller control toggle switch. The switch terminal nearest the cabin door will have 1 or 2 wires attached. Early models through S/N 1820 have 1 wire and S/N 1821 and later have 2 wires. Remove one wire that goes to the old connector. Leave the second wire, if it exists. Attach the new "A" wire to this switch terminal.
- d. The center-most switch terminal will have 2 wires attached. One of these wires supplies filament voltage to the tube in the old governor. The filament wire goes to the old connector. Remove it from the switch terminal and replace the screw leaving the other wire connected.
- e. The old connector will now have only 3 wires still connected to the aircraft. One of these is a ground wire. Identify it and disconnect it and ground the new wire "B" to this place.
- f. The 2 remaining wires go to the propeller control relays that are located on the inside of the carpeted fairing that has the mechanical landing gear position indicator. In early models (through SN1820) these wires go to the switch where they are paralleled with the relay wires. In these models, simply replace the old connector C and D wires with the new connector C and D wires. In the later models, the C and D wires go directly to the relays. Identify the wire that goes to pin "C" of the old connector. Cut the wire on the relay side of the scissor type connector and connect the new wire "C" using the crimp connector supplied. Repeat for wire "D".
- g. The old connector should now be completely disconnected from the aircraft. Set it aside.

# AIRBORNE ELECTRONICS

## 4. CONNECTION OF LEAD "H" TO RIGHT MAGNETO:

- a. Push the "H" lead lug and resistor assembly through the firewall "P" leads (mag grounding leads) grommet. In some aircraft, this grommet has become congested with numerous add-on wires such as EGT wires. If this is the case, cut the "H" lead 1 foot from the 7 pin connector and feed the cut end through the grommet from the engine side and splice to the connector lead on the cabin side.
- b. Connect the "H" terminal to the right magneto radio filter screw terminal that has the mag "P" lead connected to it. Secure the "H" lead to the "P" lead using cable ties.

## 5. KNOB AND PLACARD:

- a. Replace the control column collar.
- b. Dry fit the prop control placard over the shoulder nut to check clearances.
- c. Remove the release paper from the placard and stick in place.
- d. Rotate rheostat shaft full CW and then install knob with the dot at 12 o'clock. The knob should be installed so that the detent pall is just depressed.

## 6. MOUNTING THE GOVERNOR:

- a. Mount the governor so that the male connector faces down and the name plate faces the cabin door.
- b. Plug the 7 pin cable connector onto the governor connector and turn the locking ring clockwise to lock in place.

## 7. GO TO GROUND TEST PROCEDURE.

### GROUND TEST

If the governor has not been preset to the desired take-off RPM, remove the 1/4 inch plug button on the governor cover by prying at the lip with a knife. Stow a small screwdriver and the Allen drive wrench used to install the knob on board the aircraft now so you don't forget them later at the flight test. If a specific take off RPM was not requested, the governor will be set to 2300 rpm.

*Note: The old governor will drive the prop even when the engine is not running. Some Bonanza operators may be accustomed to ground testing the old governor by manually running the prop to an intermediate pitch, and then switching to AUTO. The old governor will return the prop to full fine pitch even with the engine not running. The new governor will not take this action*

## AIRBORNE ELECTRONICS

*without the magneto signal produced only when the engine is running. This characteristic was purposely designed into the 350A. If the old governor loses its RPM signal due to a broken FLEX cable or "T" drive, it will drive the prop to an over speed. If the new governor lose its RPM signal, it takes no action.*

Position the aircraft so there is no debris under the propeller. With the propeller in the OFF (not AUTO) position, start and warm the engine. Advance the throttle to increase the RPM to 1900. Turn the prop control knob to its full clockwise stop. Position the prop switch to AUTO and turn the knob back and forth and observe that RPM changes both down and up. If the system does not perform as described above, proceed to the SERVICE NOTES.

*Note: Typically, the governor will produce oscillating increase and decrease commands if it is asked to govern at a low (1800) RPM on the ground. The servo dynamics are designed for best performance in flight, not on the ground.*

Proceed to FAA written PREFLIGHT PROCEDURE in the separate package of XEROXED sheets and then to the FLIGHT TEST PROCEDURE on page 4 of this package.

---

### FLIGHT TEST PROCEDURE

1. Set the propeller to high RPM using the prop toggle switch during pre-takeoff check and leave the switch in the off position. Control the RPM manually during take-off and climb.
  2. When safe to proceed with tests, turn the control knob to approximate mid-range and turn the switch to AUTO. The RPM can now be changed with the knob and should hold constant (with slight dynamic and static errors) when throttle or pitch attitude is changed.
  3. Turn the knob full clockwise. The RPM should settle at the preset take-off RPM (2300 if take-off RPM was not specified with order). If this RPM is in error, the panel tach accuracy should be suspected (see Service Note 5).
  4. The take-off RPM can be adjusted with a small screwdriver after removing the plug-button on the governor cover (It is wise to remove this button before flight). Turning the adjustment clockwise (looking into the hole) increases the take-off RPM.
  5. The knob may be adjusted relative to it's shaft to position the detent at the desired cruising RPM.
- 

### IF TROUBLE, WHERE TO START

1. Manual operation doesn't work: Go to MANUAL WIRING, S/N 9, page 11.
2. Manual works but AUTO does nothing: Go to BLOWN FUSES, page 11, then to OPEN MAG SENSE LEAD, page 11, then to AIRFRAME SYSTEMS TEST, page 5. If still in trouble, contact AIRBORNE.
3. AUTO will increase RPM but won't decrease or visa versa: Go to RELAY AND LIMIT SWITCH TEST, page 7, paragraph 7, then to INTERMITTENT PROBLEMS, page 10.

## AIRBORNE ELECTRONICS

4. RPM oscillates up and down in flight: Go to BRUSH SERVICE, page 9, then WRONG GEARS, page 8.
  5. Prop goes to full coarse pitch when first switched to AUTO: Governor leads C and D are probably reversed. Go to AIRFRAME SYSTEMS TEST, step 7, page 7 to confirm.
  6. Governor seems overactive or intermittent in operation: Go to DEFECTIVE MAGS, page 8, then to INTERMITTENT PROBLEMS, page 10.
  7. Unable to set TAKE-OFF RPM: Go to INACCURATE PANEL TACHOMETER, page 9.
- 

### Service Note 1

#### **AIRFRAME SYSTEMS TEST**

*(Formerly called "Automatic Propeller Control Troubleshooting Procedure")*

This simple procedure should be useful for isolating faults in the installation wiring, propeller control relays or the propeller limit switches.

It is possible to have normal MANUAL operation with faulty relays, limit switches, or associated wiring. The relays and limit switches are not involved with manual operation on aircraft serial number D-1821 or later and on earlier aircraft that have been updated to the later wiring (see MANUAL WIRING, S/N 9, page 11). Therefore, AUTO malfunction with proper MANUAL function does not imply a governor problem. The great majority of problems we have found in the past 19 years have been associated with faulty wiring.

This procedure assumes MANUAL operation is normal. If not, go to MANUAL WIRING, page 11.

#### **1. AIRCRAFT CONTROL SETTINGS:**

- a. Aircraft MASTER switch OFF.
- b. Propeller control switch OFF (not in AUTO)
- c. Propeller RPM knob full CW.
- d. Magneto switch OFF.

#### **2. DISCONNECT THE 7 PIN CONNECTOR FROM THE 350A GOVERNOR.**

#### **3. GROUND CONTINUITY TEST:**

- a. Connect an ohmmeter to pin B of the female connector and to airframe ground. (A probe can be formed from 0.032 or 0.041 safety wire.)
- b. With the ohmmeter set to the lowest Ohms range, the resistance measured should be comparable to that indicated by shorting the ohmmeter probes.

## AIRBORNE ELECTRONICS

### 4. MAGNETO RESISTOR LEAD CONTINUITY TEST:

- a. Connect the ohmmeter to pin H of the female connector and to airframe ground and turn ignition switch to BOTH.
- b. The resistance should be 10000 ohms plus or minus 10%.
- c. Return the ignition switch to OFF.
- d. Note: It is normal for the ohmmeter indication to remain the same when switching between BOTH and OFF. If the circuit is open when switched to BOTH but 10000 ohms when switched to off, you may have the dangerous, and not uncommon, situation of an open grounding circuit internal to the mag.
- e. Make sure the ignition switch is OFF.

### 5. CONTROL RHEOSTAT TEST:

- a. Connect the ohmmeter to pins E and F using safety wire.
- b. The resistance should be less than 100 ohms.
- c. Turn the knob to the full CCW stop.
- d. The resistance should be 10000 ohms.
- e. Observe that the resistance changes smoothly between the above extremes when the knob is rotated from stop to stop.

### 6. 12 VOLT SUPPLY TEST:

- a. Connect voltmeter positive lead to pin A of female connector.
- b. Connect voltmeter negative lead to airframe ground.
- c. Turn on aircraft master switch by turning the ignition switch to the BAT position and positioning the BATTERY toggle switch to ON.
- d. There should be no voltage indication with the propeller toggle switch OFF. (not in AUTO)
- e. Position the propeller toggle switch to AUTO.
- f. The voltmeter should indicate 12 volts.
- g. Note: The voltmeter should also read zero with the switch in the manual pitch control positions.

## AIRBORNE ELECTRONICS

### 7. RELAY AND LIMIT SWITCH TEST:

- a. Position propeller to full fine pitch using the prop toggle switch. Turn BATTERY toggle switch OFF.
- b. Connect pin A to pin D with a piece of .032 to .041 solid wire formed in a "U" shape.
- c. Turn battery switch ON and propeller toggle switch to AUTO.
- d. The propeller motor should run the propeller to full coarse pitch and then stop when the full coarse limit switch opens. If not, go to step 8.
- e. Turn BATTERY switch OFF and remove "U" shaped wire.
- f. Connect pin A to C with "U" shaped wire.
- g. Turn BATTERY switch ON and propeller toggle switch to AUTO.
- h. The propeller motor should run the propeller to full fine pitch and then stop when the full fine limit switch opens. If not, got step 9 after turning off the BATTERY switch and the prop switch.

8. Connecting pin A to pin D or pin C is equivalent to what the governor does to affect an increase pitch or decrease pitch command. If the motor fails to run in step 7d, it is possible that the limit switch wires have been reversed at the propeller during reinstallation of the propeller after service. This is not uncommon. The following procedure will verify such a reversal. If the motor runs in 7d but fails in 7h, skip to step 9.

- a. Connect pin A to D with "U" shaped wire. Turn BATTERY switch ON.
- b. Switch propeller toggle switch to DECREASE RPM for 10 seconds causing ring gear to move enough to close the full fine limit switch.
- c. Switch to AUTO, if motor runs and continues to run even after full coarse pitch is reached, the limit switch wiring is very likely reversed at the propeller. The limit switch disconnects can be seen through the left cowling air intake. They are insulated with plastic sleeves. If motor does not run, go to step 9.

9. If motor does not run in step 7c, 7h, or 8c, perform the following:

- a. Switch back and forth between AUTO and OFF while listening for operation clicks of the increase pitch relay. On aircraft serial no. 1821 and later the relays are located on the right inside of the carpeted fairing that has the landing gear position indicator window. On earlier models the relays are located on the underside of the glareshield near the voltage regulator.
- b. If no clicks are heard, troubleshoot the relay coil circuit. If clicks are heard,



# AIRBORNE ELECTRONICS

troubleshoot the relay contact circuit. See wiring diagram, figure A.

10. If still in trouble, call AIRBORNE.

---

## Service Note 2

### **DEFECTIVE MAGNETOS**

Weak impulse springs, badly worn rubber couplings, badly burned breaker points, or defective P lead radio filters can all cause jitter in the timing of the pulses from the magneto, confusing the governor, causing it to operate excessively.

A simple test for this is to switch lead H to the left magneto and compare control operation.

Sometimes you should be suspicious of both magnetos. The 350A governor has been credited many times with detecting defective mags. In one notable case, both mags were found to be installed with Eisemann single piece composite couplings instead of the 3 piece rubber and metal Bendix couplings. The Eisemann couplings were coming apart and pieces were falling into the accessory case.

We have sometimes found CB automotive radio filters in place of aircraft magneto filters. They are not electrically equivalent.

---

## Service Note 3

### **PROPELLER MOTORS WITH WRONG GEARS INSTALLED**

215-210 propeller control motors have been found in the field with wrong gears installed. The worm gear and the output helical gear from the Bonanza flap actuator will fit the propeller motor but will result in a 3 to 1 smaller gear ratio. See figure B.

A simple test can be performed to determine if wrong gears are installed. With the engine not running, measure the time required to operate the propeller between pitch extremes manually. This time should be between 16 and 32 seconds. If flap actuator gears are installed, the time will be between 6 and 12 seconds. If wrong gears are suspected, the gear box cover can be easily removed without removing the motor.

The smaller gear ratio can result in unstable operation of the model 350A governor. Also, the smaller ratio is potentially dangerous whether or not the aircraft is equipped with a governor, as the reduced gear-motor friction can allow the prop to drift toward full coarse pitch with no voltage applied. In the event of an electrical failure, this situation could become serious.

---

## Service Note 4

### **ELECTRIC PROPELLER MOTOR BRUSH SERVICE**

It is not necessary to remove the propeller pitch control motor to service its brushes. Releasing the circular clamp that secures the motor to its mounting bracket will allow the motor to pivot outward away from the engine case providing easy access to the inboard brush holder.

## AIRBORNE ELECTRONICS

In many cases, we have found wrong brush assemblies in these motors. The correct part is PN 31-408 and is usually stocked by Beech dealers. This part can be identified by its stiff spring which is wound with .027 inch diameter spring wire. Typically, the wrong part found is a landing gear motor brush which has spring wire diameter less than .020 inch.

The purpose of the stiff brush spring is to increase turning friction of the motor. Insufficient friction can cause RPM oscillation with both the old governor and the AIRBORNE ELECTRONICS governor. In the extreme, insufficient friction can produce the dangerous situation of the motor rotating slowly in flight with no voltage applied. The propeller forces causing this rotation can take the prop all the way to full coarse pitch over a period of several minutes. In the event of an electrical failure, this condition could become serious.

The following precautions should be observed when installing new brushes:

The copper braid that connects the brass spring cap to the graphite brush can become severely twisted and knotted as the brush holder cap is screwed into place. Tension in this copper braid can reduce friction or actually pull the brush away from the armature commutator. The condition can develop with time, as the graphite wears, increasing the extension of the braid and spring.

To prevent this condition, the braid should be prewound in the CCW sense so that it will relax when the cap is screwed home.

The composition brush holder ferrules and caps are fragile and it is important to start screwing the caps square to the ferrule as cross-threading can crack the ferrule or destroy the fine screw threads. The Beech part number for the cap is 35-364151-25 and the price, as of this writing, is \$11.90 each. The part number for the ferrule is 35-364-151-15 with uncertain price.

Beech has tooled a new, molded, brush holder assembly. The new part number is 35-364151-61 and is on the order of \$20.

---

### Service Note 5

#### INACCURATE PANEL TACHOMETER

High time panel tachometers can display considerable error in indicated RPM. The 350A governor maximum RPM adjustment is accurately factory preset to 2300 RPM or a requested RPM. If the indicated maximum RPM on the initial flight (before changing the screwdriver adjustment) is not as expected, tach accuracy should be suspected.

A simple tachometer accuracy check can be made as follows: At night, position the aircraft with its tail toward a mercury vapor or fluorescent lamp. These lamps produce 120 pulses of light per second. Start the engine and increase the RPM with the throttle to approximately 1800 RPM. Adjust the throttle until an image of a fuzzy 4-bladed, stationary, propeller is obtained, and then quickly read the panel tach. The indicated RPM should be 1800.

Replacement AC tachometers can be purchased almost anywhere for around \$50.00. Be sure to specify cruise RPM to get the right hourmeter gear ratio.

# AIRBORNE ELECTRONICS

## Service Note 6

### **INTERMITTENT PROPELLER CONTROL PROBLEMS**

Perform step 7 of Service Note 1, page 7. While the prop motor is running, disturb (jiggle) the wiring in the vicinity of the prop motor. This will probably require an assistant to turn the master on and off and move the "U" shaped jumper. Do the same for the propeller associated wiring behind the panel. This test has a high success rate. If this shotgun approach was unsuccessful, continue with the following "test lamp" approach.

If the propeller control system performs correctly on the ground but not in the air, the malfunction could be associated with, in order of probability, system wiring, the limit switches, the relays, the right magneto or the governor.

The malfunction can be isolated by connecting a pair of small indicator lamps into the system at various points and observing the lamps during a period of improper operation.

The first test will determine if the governor is operating properly.

The governor relay outputs are leads C and D. See figure A. These wires are connected to the 7 pin female governor connector at one end and to crimp connectors at their other ends. These outputs supply 12 volts to the appropriate relay when a pitch change is required. 12 volts at lead C should decrease pitch (increase RPM) and 12 volts at lead D should increase pitch (decrease RPM).

By connecting small 12 volt lamps between lead C and ground and between lead D and ground, governor operation can be observed in flight. Number 52 or 53 pilot lamps or 12 volt post light lamps can be used.

Changing the cockpit RPM knob in flight should cause the appropriate lamp to light until the selected RPM is reached. The "C" lamp should light when the RPM is too low and the "D" lamp should light when the RPM is too high. If not the governor is defective and should be returned for repair. Call AIRBORNE for shipping instructions.

If the lamps behave appropriately, the malfunction is not associated with the governor but with some other part of the system.

If both lamps flash on and off in a fast, erratic way, suspect the right magneto. Try switching lead H to the left magneto. See Service Note 2, page 8.

If the lamps light appropriately, but RPM doesn't respond, suspect the limit switches and the limit switch wiring just behind the propeller. Instances have been found wherein the system behaved correctly on the ground but the slipstream in flight would deflect the wiring behind the propeller causing an open circuit.

The lamps can be connected across the relay coils to indicate if the relays are receiving the proper energizing voltages. The positive sides of the relay coils are connected to the C and D outputs of the governor and the negative sides are connected through the limit switches to ground. A relay will not operate if the limit switch circuit is open for any reason.

With the propeller in an intermediate pitch position on the ground, the limit switches can be switched from their closed position to their open position by lifting their roller arms gently. A click should be heard as the arm is lifted and the switch should change from an electrical short to an open.

# AIRBORNE ELECTRONICS

## Service Note 7 BLOWN FUSES

The AIRBORNE ELECTRONICS 350A contains two 1/2 amp fuses. If either of these fuses is open the governor will not function.

Early Bonanza batteries are frequently accidentally reverse connected because of the confusing coloring of the battery leads. Typically, the positive lead is black and the negative lead is amber. Battery reversal will blow the "A" fuse.

In any event, if the governor is dormant, these fuses should be checked before further action is taken.

Using a #2 posi-driver (or a non-worn #2 phillips screwdriver) remove the 4 screws in the corners of the die-cast governor cover. Do not worry about warranty. It will be honored even though the cover has been removed. The two glass "AGC" fuses will be obvious once the cover is removed. Examine the fuses with a magnifying glass or an ohmmeter.

Replacement 1/2 amp "AGC" fuses are available at any electronics store.

---

## Service Note 8 OPEN MAG LEAD

If the governor has been working well for some time and suddenly goes dormant, the first thing to check is the resistor-lug assembly attached to the right magneto radio filter.

Give the white wire a tug to see if the resistor lead is broken inside the heat shrink sleeve. If the resistor lead is broken, call AIRBORNE for a new assembly.

---

## Service Note 9 MANUAL WIRING

Starting with serial number D-1821, Beechcraft made a change in the electric propeller wiring to simplify the manual control system rendering it more reliable.

Straight 35's and A models through serial D-1820 were wired such that the panel propeller switch energizes the propeller control relays when switched to the INCREASE or DECREASE RPM positions. The relays, in turn, supply voltage to the pitch change motor. Aircraft D-1821 and later are wired with the panel switch supplying motor current directly. See figures C and D.

Failure of a relay, limit switch, or associated wiring, will affect only automatic operation in the later aircraft but will affect both manual and automatic operation in the earlier aircraft. For this reason, some of the earlier aircraft have been updated to the later wiring.

Which wiring system is installed can be determined by the following ground procedure: With the engine off and the master switch on, run the prop to pitch extremes using the propeller toggle switch. If the pitch control motor stops at pitch extremes, the early wiring is in place. If the motor continues to run at the pitch extremes, making a clicking sound, either the later wiring is in place or the limit switch system is faulty. After testing, it is important to leave the aircraft with the prop returned to full fine pitch to prevent a future start-up and take-off attempt at a coarse pitch setting.

Several of our customers with an automatic malfunction but normal manual operation have made the seemingly obvious assumption that the governor was at fault. In almost all instances, using

# AIRBORNE ELECTRONICS

Service Note 1 has isolated the problem to faulty wiring.

---

## Service Note 10 HIDDEN SCREWS

Some G models have been found with decorative plastic covering the heads of the 3 flat head screws that secure the control knob bearing and flex shaft.

Mark the approximate positions of the screw heads under the plastic by using the template on figure E. Drill three 1/4 inch hole just through the plastic. Grind the tip of a 1/4 drill bit flat to finish drilling the plastic to expose the screw heads. Sideways forces can be used to "oblong" the holes as necessary to completely expose the screw heads. The included control placard will cover the holes.

---

## Service Note 11 WEIGHT AND BALANCE

Removed 3.75 lbs. at 60 inches for a moment of minus 225. Added 1.0 lb. at 60 inches for a moment of plus 60.

Net change: Minus 2.75 lbs. at 60 inches for a moment of minus 165.

Compute new empty CG as follows:

1. Subtract net change in lbs. from old empty weight for new empty weight. Adjust useful load accordingly.
  2. Subtract net change in moment from old empty moment for new empty moment.
  3. Divide new empty moment by new empty weight for new empty CG.
- 

**AIRBORNE ELECTRONICS**  
2655 N. FITCH MTN. RD.  
HEALDSBURG, CA 95448  
(707) 542-6053

| QTY | PRODUCT | NEXT ASSY DWG | NO. | DESCRIPTION OF CHANGE     | SCO | DATE    | BY     |
|-----|---------|---------------|-----|---------------------------|-----|---------|--------|
|     |         |               | 1   | ADDED FIREWALL CONNECTOR  |     | 11-3-73 | R.S.K. |
|     |         |               | 2   | ADDED PARTS REFERENCE.    |     | 5-18-73 | R.S.K. |
|     |         |               | A   | ADD AIRCRAFT EFFECTIVITY. |     | 3-17-76 | RCK    |

FIGURE A

AIRBORNE ELECTRONICS  
2655 N. Fitch Mtn. Rd.  
Healdsburg, CA. 95448

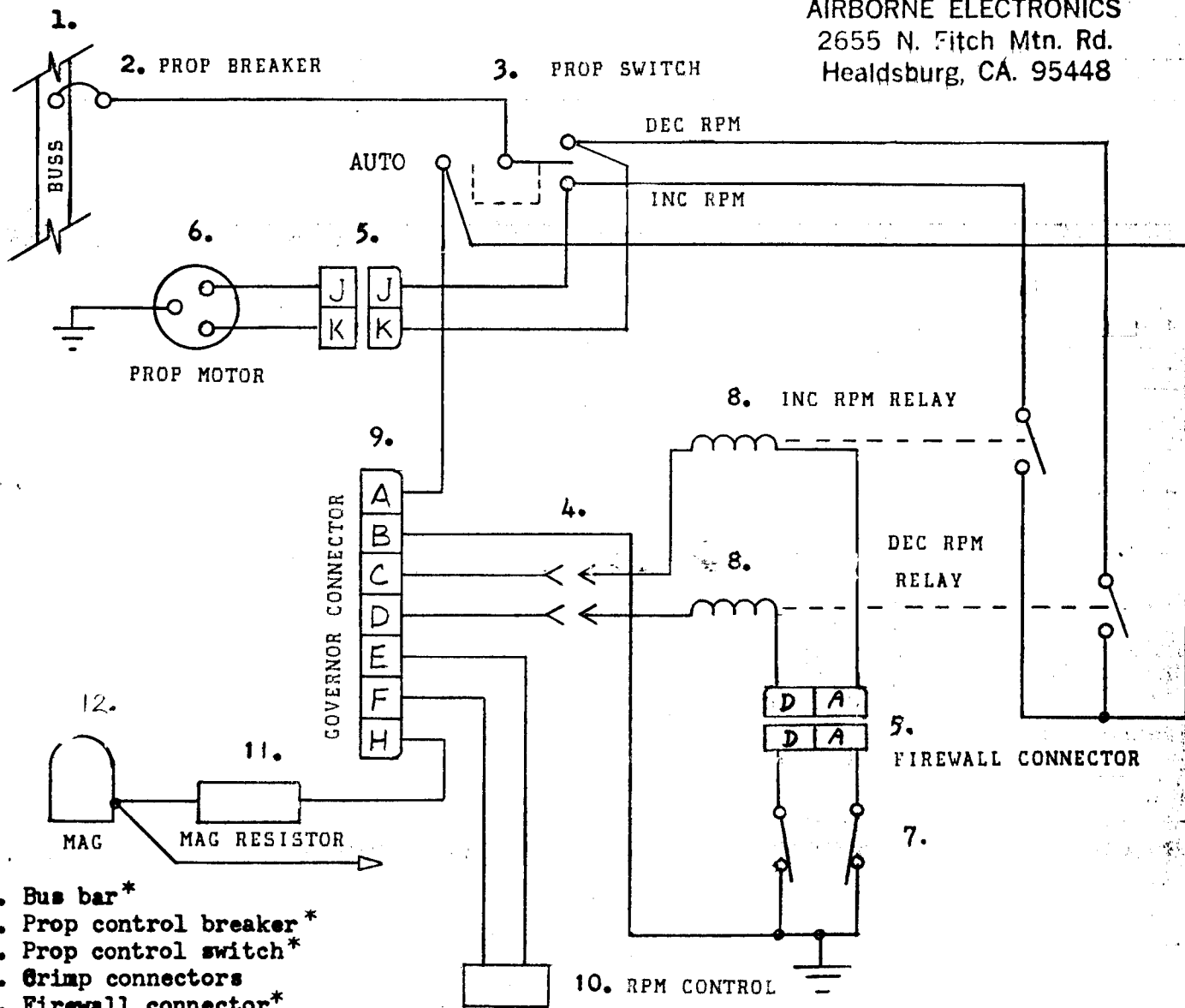

- 1. Bus bar\*
- 2. Prop control breaker\*
- 3. Prop control switch\*
- 4. Crimp connectors
- 5. Firewall connector\*
- 6. Prop control motor\*
- 7. Limit switches\*
- 8. Relays\*
- 9. SSAPC cable connector
- 10. Panel control

11. Isolating resistor  
12. Magneto\*  
\* Existing parts, not supplied with Model 350A installation kit. Refer to 0350-0505 for supplied parts description.

| ITEM                                  | QTY    | PART NUMBER     | DESCRIPTION              |
|---------------------------------------|--------|-----------------|--------------------------|
| TOLERANCES UNLESS OTHERWISE SPECIFIED |        |                 |                          |
| FRACTIONS ± 1/64                      |        | DECIMALS ± .005 | ANGLES ± 1°              |
| DO NOT SCALE DRAWING                  |        |                 |                          |
| DRAWN                                 | R.S.K. | 7-20-72         | SCALE ~                  |
| CHKD.                                 | RCK    | 3-17-76         | PRODN. CHKD. RCK 3-17-76 |
| ENG. APPD.                            | RCK    | 3-17-76         | PRODN. APPD. RCK 3-17-76 |
| MAT'L.                                | ~      |                 |                          |
| MAT'L. SPEC. NO.                      |        |                 |                          |

This Document is the Property of \_\_\_\_\_ and Shall Not Be Copied, Reproduced, Used in the Manufacture or Sale of Apparatus or Disclosed to Others Without Permission.

DIVISION: AIRBORNE ELECTRONICS

SSAPC.  
WIRING DIAGRAM

All models with APC previously installed

NO. A 0350-0103

FIGURE B

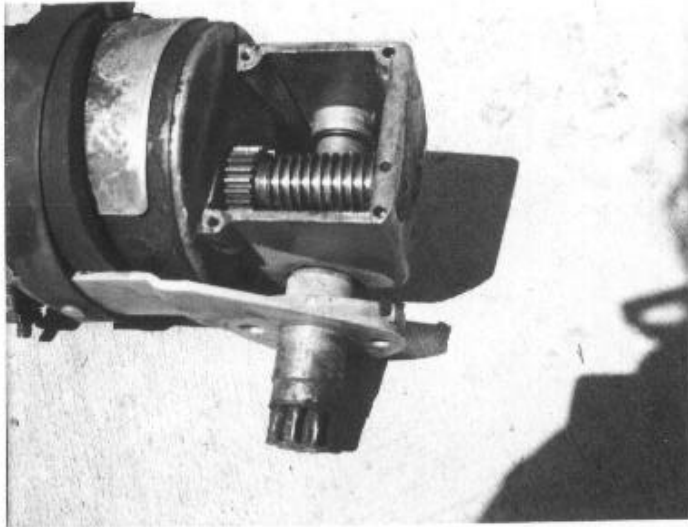

PROPELLER PITCH  
MOTOR WITH CORRECT  
GEARS INSTALLED

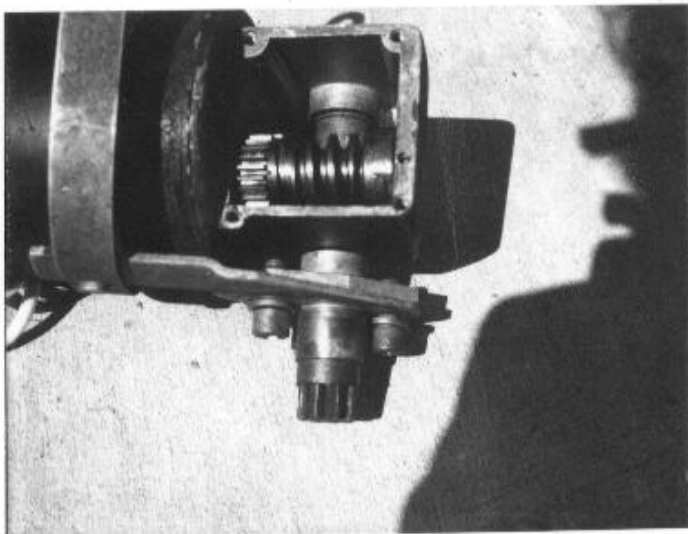

PROPELLOR PITCH  
MOTOR WITH FLAP  
ACTUATOR GEARS  
INSTALLED

# FIGURE C

## ORIGINAL FLIGHT RESEARCH GOVERNOR WIRING; EARLY MODELS

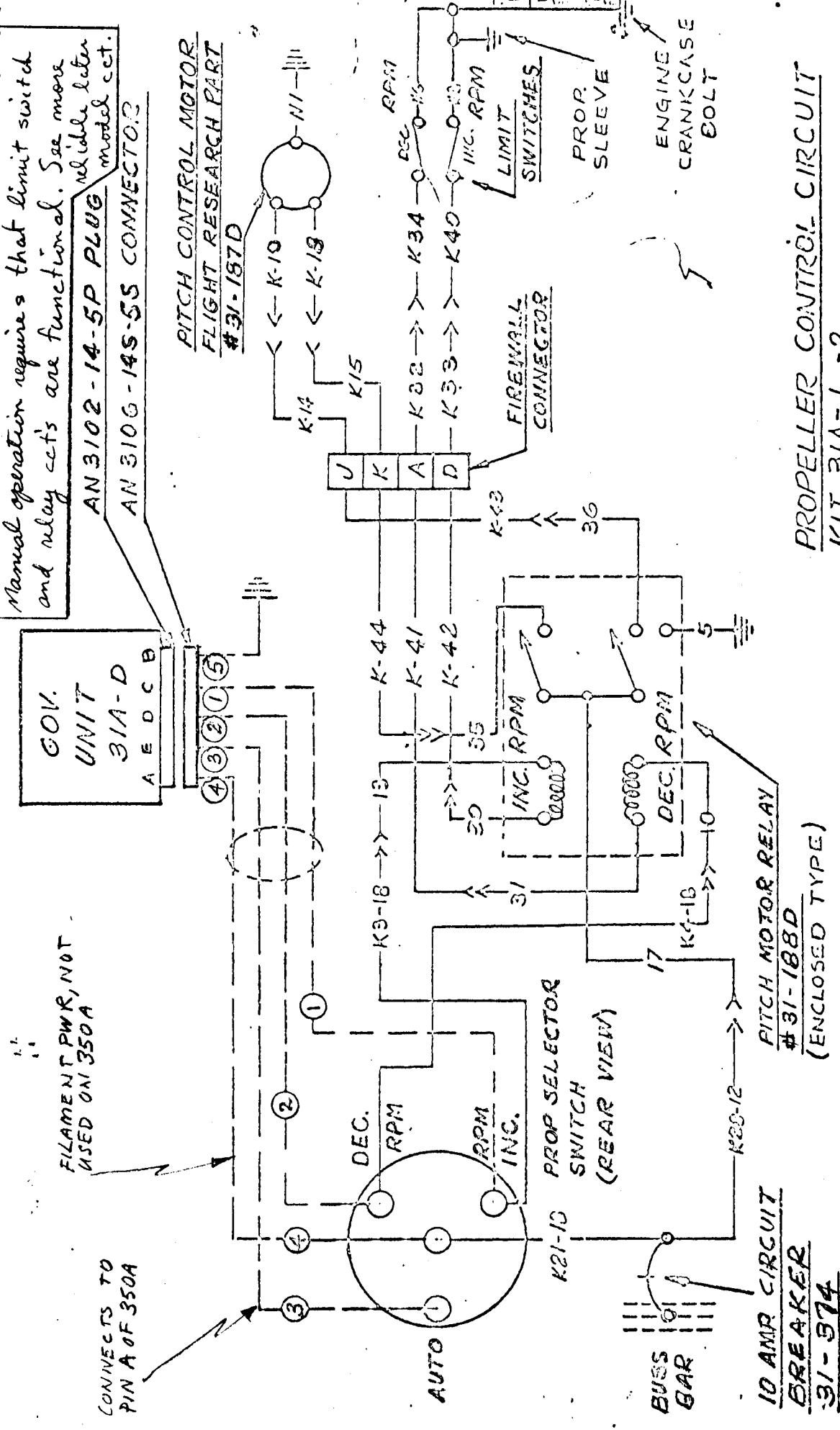

FIGURE C

PROPELLER CONTROL CIRCUIT  
KIT 31A-1,-2  
GOVERNOR UNIT 31A-D  
BEECHCRAFT DI-D1820

REVISED - 6-6-50

NOTE: MAKE CERTAIN THAT ALL QUICK DISCONNECTS MAKE TIGHT JUNCTIONS.



# FIGURE D

## PIGNAL FLIGHT RESEARCH GOVERNOR WIRING; LATER MODELS

More reliable; Prop motor wired directly to panel switch so manual operation does not involve limit switch and relay acts

CONNECTS TO PIN A OF 350A  
FILAMENT PWR, NOT USED ON 350A

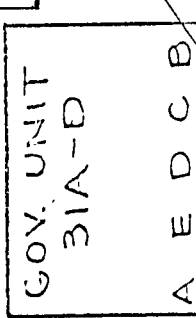

AN 3102-14-5P PLUG  
AN 3106-14S-5S CONNECTOR

PITCH CONTROL MOTOR  
FLIGHT RESEARCH  
PART # 31-187 D

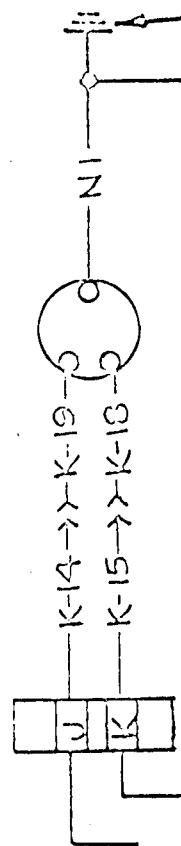

SCREEN ON GEAR BOX OF PITCH MOTOR

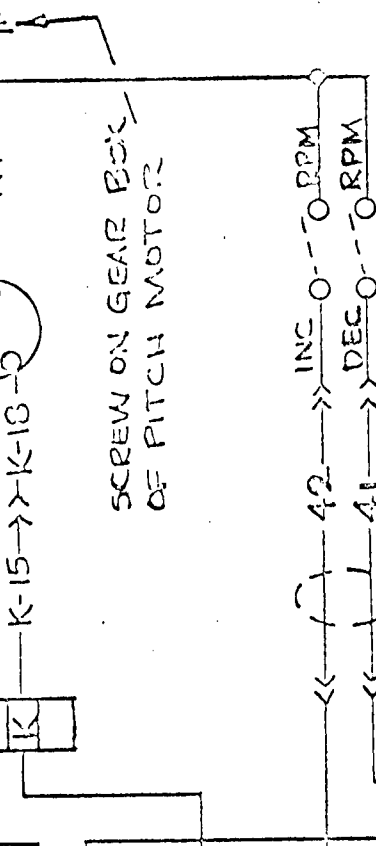

THRU GROMMET HOLE IN FIREWALL  
LIMIT SWITCHES

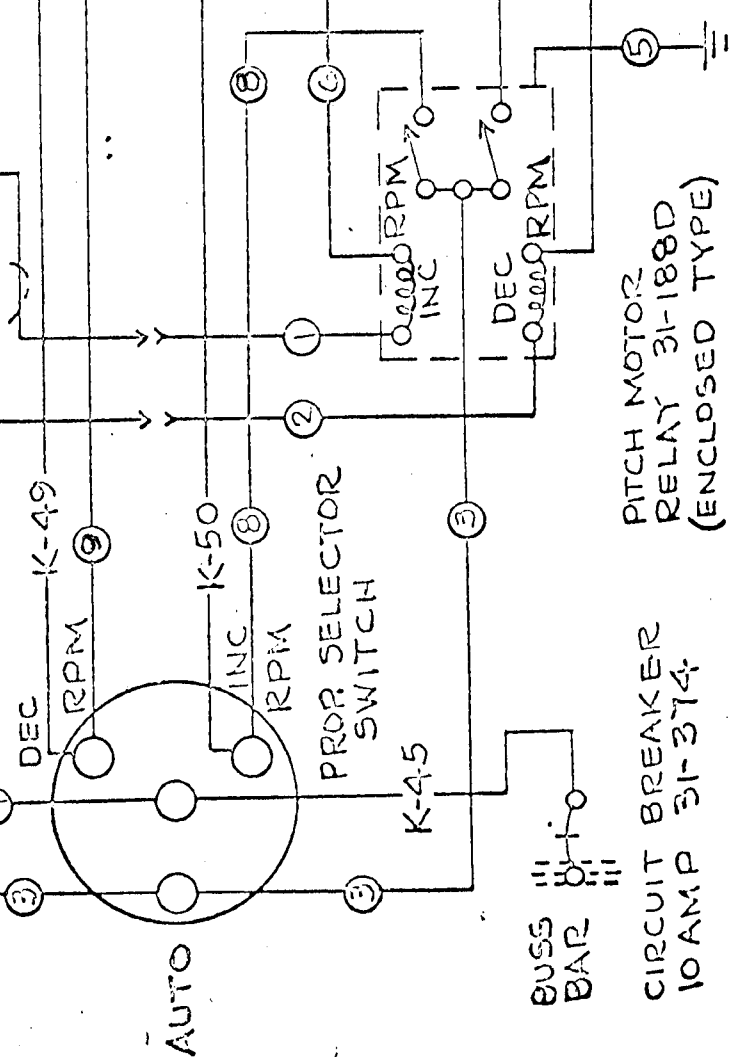

PITCH MOTOR RELAY 31-188D (ENCLOSED TYPE)

CIRCUIT BREAKER 10 AMP 31-374

PROPELLER CONTROL CIRCUIT  
KIT 31A-3, -4, -5, -7, -8, -8A  
GOV. UNIT 31A-D  
BEECHCRAFT D1821 & AFTER

NOTE  
MAKE CERTAIN THAT ALL QUICK DISCONNECTS MAKE TIGHT JUNCTIONS

FIGURE D

FLIGHT RESEARCH ENGINEERING

| QTY | PRODUCT | NEXT ASSY DWG | NO. | DESCRIPTION OF CHANGE                                       | SCO | DATE    | BY  |
|-----|---------|---------------|-----|---|-----|---------|-----|
|     |         |               | 1   | ADDED MATERIAL LIST   |     | 4-7-73  | RSK |
|     |         |               | 2   | ADDED PLACARD (6)   |     | 5-18-73 | RSK |
|     |         |               | 3   | REMOVED FELT WASHER AND ADDED DETENT SLOT, CORRECT MAT LIST |     | 7-22-74 | RSK |
|     |         |               | 4   | CORRECT ITEM 5  |     | 4-15-75 | RSK |
|     |         |               | A   | REVISED BILL OF MATERIAL AND ADD AIRCRAFT EFFECTIVITY       |     | 3-17-76 | RSK |
|     |         |               | B   | REMOVED SHOULDER NUT DETAIL RE VIEW PANEL CONTROL MOUNTING  |     | 4-27-76 | RSK |

# FIGURE E

## — INSTALLATION —

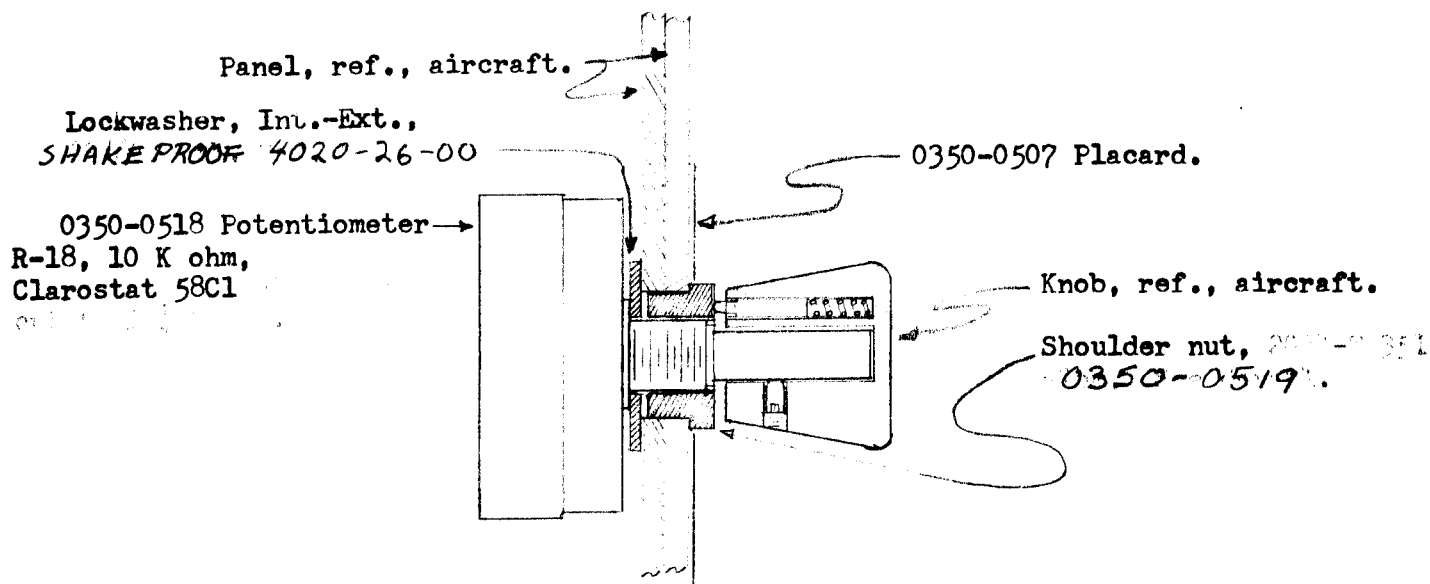

12 O'clock

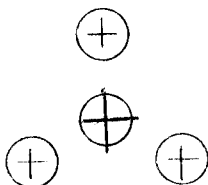

Template for Locating  
Three 1/4" Couterbores  
Spaced 120° on 7/16 Radius

AIRBORNE ELECTRONICS  
2655 N. Fitch Mtn. Rd.  
Healdsburg, CA. 95448

| ITEM   | QTY  | PART NUMBER                          | DESCRIPTION   |
|--|--|--------------------------------------|---|
| <b>TOLERANCES UNLESS OTHERWISE SPECIFIED</b><br>FRACTIONS ± 1/64    DECIMALS ± .005    ANGLES ± 1° |  |                                      | This Document is the Property of AIRBORNE ELECTRONICS, and Shall Not Be Copied, Reproduced, Used in the Manufacture or Sale of Apparatus or Disclosed to Others Without Permission. |
| <b>DO NOT SCALE DRAWING</b>  |  |                                      |   |
| DRAWN <i>RSK</i> 4-25-76<br>CHKD. <i>RSK</i> 4-25-76<br>ENG. APPD. <i>RSK</i> 4-25-76<br>MAT'L. —  | SCALE FULL<br>PRODN. CHKD. —<br>PRODN. APPD. — | DIVISION: AIRBORNE ELECTRONICS, INC. |   |
| MAT'L. SPEC. NO. —<br>FINISH —   |  |                                      | NO. <b>A 0350-0102</b> CHANGE <b>- B</b>  |

PANEL CONTROL MOUNTING

| QTY | PRODUCT | NEXT ASSY DWG | NO. | DESCRIPTION OF CHANGE                                 | SCO | DATE     | BY     |
|-----|---------|---------------|-----|---|-----|----------|--------|
| -   | -       | -             | 1   | CHANGED MTG. OF CHASSIS UNIT                          |     | 11-2-72  | R.S.K. |
| -   | -       | -             | 2   | CHANGED POS. OF ADAPTER PLATE                         |     | 10-14-74 | R.S.K. |
| -   | -       | -             | A   | ADD PART NUMBERS                                      |     | 3-17-76  | RCK    |
| -   | -       | -             |     | AND EXTEND AIRCRAFT EFFECTIVITY                       |     |          |        |
|     |         |               | B   | CHANGED ITEM 3 WAS 2-56, IS 4-40<br>ADDED BEECH NO'S. |     | 4-27-76  | RCK    |

### FIGURE F

AIRBORNE ELECTRONICS  
2655 N. Fitch Mtn. Rd.  
Healdsburg, CA. 95448

BEECH# 35-324069

CENTER INSTRUMENT  
PANEL CHANNELS (REF.)  
(AIRCRAFT ORIGINAL STRUCTURE)

BEECH # 35-324021  
SUPPORT- FWD  
PULLEY BRKT.  
(REF AIRCRAFT  
ORIGINAL  
STRUCTURE)

SPACER NUT, REF.  
3 1/2" LONG 3/8" DIA.  
#2024 ALUM.  
(AIRCRAFT ORIGINAL  
HARDWARE)

③ SCREWS  
4 PLACES

SPACER NUT, REF.  
3 3/4" LONG 3/8" DIA.,  
SPACERS #2024 ALUM.  
(AIRCRAFT ORIGINAL HARDWARE)

② MOUNTING ADAPTER PLATE  
DRWG. NO. 0350-0504-A

① PROP CONT. ASSY.

SCREWS,  
10-32 X 1/2 LONG, SCREWS,  
8-PLACES, REF  
(AIRCRAFT ORIGINAL HARDWARE)

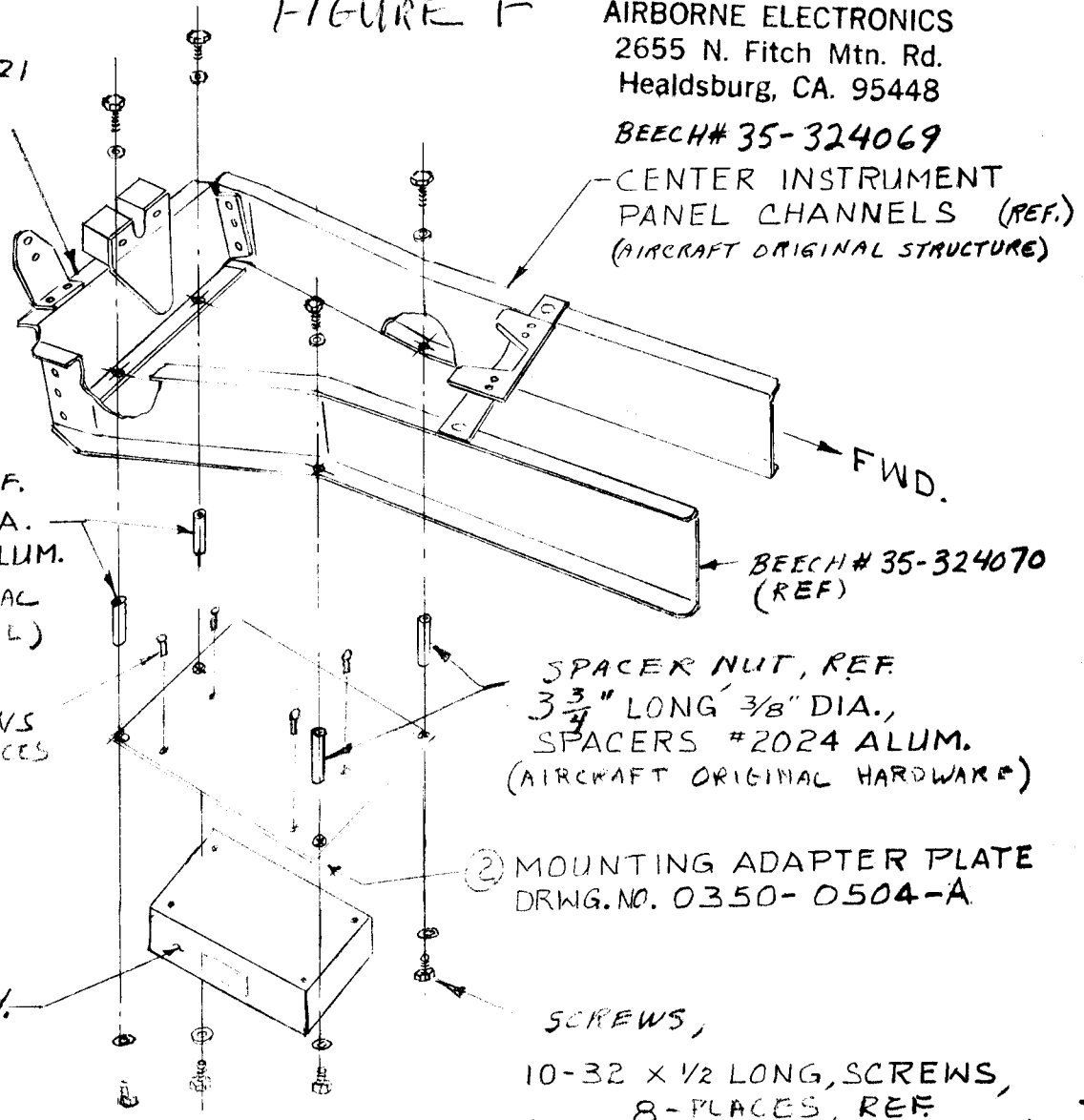

| ITEM | QTY | PART NUMBER | DESCRIPTION                                 |
|------|-----|-------------|---|
| 3    | 4   | SRM         | SCREW 4-40 X 1/4 SLOT PAN, STL.             |
| 2    | 1   | 0350-0504   | ADAPTER PLATE, MFG AIRBORNE ELEC            |
| 1    | 1   | 0350-0500   | PROPELLER CONTROL ASSY, MFG. AIRBORNE ELEC. |

|                                       |                  |              |               |
|---------------------------------------|------------------|--------------|---------------|
| TOLERANCES UNLESS OTHERWISE SPECIFIED |                  |              |               |
| FRACTIONS ± 1/64                      | DECIMALS ± .005  | ANGLES ± 1°  |               |
| DO NOT SCALE DRAWING                  |                  |              |               |
| DRAWN                                 | R.S.K.   6-22-72 | SCALE        | NONE          |
| CHKD.                                 | RCK   3-17-76    | PRODN. CHKD. | RSK   3-17-76 |
| ENG. APPD.                            | RCK   3-17-76    | PRODN. APPD. | RSK   3-17-76 |
| MAT'L.                                | ~                |              |               |
| MAT'L. SPEC. NO.                      | ~                |              |               |
| FINISH                                | BLK.             |              |               |

This Document is the Property of \_\_\_\_\_ and Shall Not Be Copied, Reproduced, Used in the Manufacture or Sale of Apparatus or Disclosed to Others Without Permission.

DIVISION: AIRBORNE ELECTRONICS

SSAPC  
CHASSIS ASSEMBLY  
MOUNTING

NO. A0350-0101 CHANGE - 8

AIRBORNE ELECTRONICS, INC.

AIRBORNE ELECTRONICS  
2655 N. Fitch Mtn. Rd.  
Healdsburg, CA. 95448

FIGURE G1

DWG. 0350-0004A

FAA APPROVED

AIRPLANE FLIGHT MANUAL SUPPLEMENT

TO

BEECH MODEL 35, A35, B35, C35, D35, E35, F35, and G35

AIRPLANE FLIGHT MANUALS

This Supplement must be attached to the FAA Approved Airplane Flight Manual when the airplane is modified by the installation of Airborne Electronics Model 350A Solid State Automatic Propeller Control in accordance with STC SA2700WE.

The information contained herein supplements or supersedes the basic manual only in those areas listed herein. For Limitations, Procedures and Performance information not contained in this Supplement, consult the basic Airplane Flight Manual.

I. Limitations  
No change.

II. Procedures  
Same as prescribed in the basic manual except:

Preflight Procedure

1. With Propeller Control Switch in the "AUTO" position, rotate the Automatic Propeller Control knob to the full increase position.
2. Advance throttle to obtain approximately 1900 rpm.
3. Turn Automatic Propeller Control knob to full decrease rpm position and observe a decrease in rpm.

FAA APPROVED DATE June 13, 1973  
REVISED June 25, 1973  
REVISED MAY 6 1978

AIRBORNE ELECTRONICS, INC.

AIRBORNE ELECTRONICS AFM SUPPLEMENT TO  
2655 N. Fitch Mtn. Rd. BEECH MODEL 35, A35,  
Healdsburg, CA. 95448 B35, C35, D35, E35,  
F35, and G35 AFM'S  
STC SA2700WE

DWG. 0350-0004A

Preflight Procedure (Continued)

4. Turn Propeller Control Switch OFF.
5. Rotate Automatic Propeller Control knob to full increase rpm position.
6. Hold Propeller Control Switch in "HIGH" rpm position until 1900 rpm is regained.
7. Hold Propeller Control Switch in "LOW" rpm position until rpm has decreased to approximately 1500 rpm.
8. Turn Propeller Control Switch to "AUTO" position and observe rpm to increase to 1900 rpm.

Inflight Procedure

With the Propeller Control Switch in the "AUTO" position, the Automatic Propeller Control knob may be used to select any desired engine rpm for all operations within the approved engine limits.

Emergency Procedure

Turn Propeller Control Switch OFF and control engine rpm manually if automatic control will not maintain selected rpm.

III. Performance  
No change.

FAA APPROVED

*Ray*  
  
 Chief, Aircraft Engineering Division  
 Federal Aviation Administration  
 Western Region

DATE June 13, 1973  
 REVISED June 25, 1973  
 REVISED 5/6/76

Department of Transportation — Federal Aviation Administration  
**Supplemental Type Certificate**

FIGURE H1

*Number* SA2700WE

*This certificate, issued to* Airborne Electronics

*certifies that the change in the type design for the following product with the limitations and conditions therefor as specified hereon meets the airworthiness requirements of Part 3 of the Civil Air Regulations.*

*Original Product — Type Certificate Number:* A-777

*Make:* Beech

*Model:* A35, 35, B35, C35, D35, E35, F35, G35

*Description of Type Design Change:*

Installation of Airborne Electronics Solid State Automatic Propeller Control Model 350A in accordance with FAA sealed Airborne Electronics Top Drawing List No. 0350-0000, Revision E1, dated April 27, 1976, or later FAA sealed revision, in place of Flight Research Engineering Corporation APC Model 31A installed in Beech airplane.

*Limitations and Conditions:*

See Page 3 of this STC.

*This certificate and the supporting data which is the basis for approval shall remain in effect until surrendered, suspended, revoked, or a termination date is otherwise established by the Administrator of the Federal Aviation Administration.*

*Date of application:* June 5, 1972

*Date issued:*

*Date of issuance:* June 13, 1973

*Date amended:* June 12, 1975; May 6, 1976;  
June 24, 1976; March 28, 1977

*By direction of the Administrator*



*[Signature]*  
 (Signature)

*Acting* Chief, Aircraft Engineering Division  
 (Title)

Any alteration of this certificate is punishable by a fine of not exceeding \$1,000, or imprisonment not exceeding 3 years, or both.

This certificate may be transferred in accordance with FAR 21.47.

United States of America *FIGURE H2*  
Department of Transportation—Federal Aviation Administration  
**Supplemental Type Certificate**  
(Continuation Sheet)

*Number* SA2700WE  
March 28, 1977

LIMITATIONS AND CONDITIONS:

The approval of this change in type design applies basically to Beech Models 35, A35, B35, C35, D35, E35, and F35, with Continental Engine E185 and Beech Propeller Hub 215-107 with blades 215-207-88; and Beech Models 35, A35, B35, C35, **D35, E35, F35**, G35 with Continental Engine E225-8 and Beech Propeller Hub 215-107 with blades 215-213-84 only. This approval should not be extended to other specific airplanes of this model on which other previously approved modifications are incorporated unless it is determined that the interrelationship between this change and any of those other previously approved modifications will introduce no adverse effect upon the airworthiness of that airplane.

FAA approved Airborne Electronics Airplane Flight Manual Supplement No. 0350-0004A, dated March 17, 1976, must be carried in aircraft.

---

*Any alteration of this certificate is punishable by a fine of not exceeding \$1,000, or imprisonment not exceeding 3 years, or both.*